



Application

Special Applications and Vehicles

Note: This bulletin now contains information on window graphic film, which was previously in Instruction Bulletin 6.7.

- Applying a graphic is more than just adhering the film to the substrate. Be sure you read and follow the instructions in all bulletins referenced in the sections you are using.

Note: Information on how to obtain bulletins is provided in **3M Related Literature** at this end of this bulletin.

Table of Contents

How to Use This Bulletin Effectively	1
Health and Safety	1
Film and Sheeting Overview	2
Tools	2
Temperature and Environment	2
Substrate Preparation	3
Application Sequence	3
Shelf Life, Storage and Shipping	3
Special Applications	4
Pump Skirts	4
Complex Curves and Contours (Concave and Convex)	5
Vehicles Applications	7
Buses	7
Conspicuity	7
Corrugations	7
Finishing	9
Painted-in Graphics	12
Roll-up Doors	13
Thermacube Trailers	14
Vehicle and Store Windows (perforated window graphic film) ..	15
Warranty and Limited Remedy	17
3M Related Literature	17

Health and Safety

Caution

When handling any chemical products, read the manufacturers' container labels and the Material Safety Data Sheets (MSDS) for important health, safety and environmental information.

To obtain MSDS sheets for 3M products:

- By fax, call 1-800-364-0768 in the US and Canada or 1-650-556-8417 for all other locations.
- Electronically, visit us at <http://www.3m.com/msds>.
- By mail, or in case of an emergency, call 1-800-364-3577 or 1-651-737-6501.

When using any equipment, always follow the manufacturers' instructions for safe operation.

How to Use This Bulletin Effectively

This bulletin gives you:

- Techniques for applying 3M™ Controltac™ Plus Graphic Films, 3M™ Scotchcal™ Graphic Films and 3M™ Scotchlite™ Graphic Films and Sheatings with pressure-sensitive or pressure-activated adhesives on special applications and vehicles.

For the best results:

- Use this bulletin in conjunction with Instruction Bulletin 5.5, *General Procedures for Interior and Exterior Dry Applications*.
- To prepare the substrate prior to graphic application, see Instruction Bulletin 5.1, *Application, Substrate Selection, Preparation and Substrate-specific Application Technique*.
- If you are applying 3M Graphic Films with Comply™ Adhesive, use this bulletin in conjunction with Instruction Bulletin 5.31.
- If you are applying 3M films to a vehicle, refer also to Instruction Bulletin 5.36, *Application: Special Considerations for Auto Graphics*.

Caution

Any activity performed for a long period of time in an awkward position or with a high amount of force is potentially a risk for causing musculoskeletal strain, pain or injury. When applying graphics, follow these practices to improve comfort and avoid injury:

- Alternative your tasks during the application.
- Schedule regular breaks.
- Perform stretches or do exercises to improve circulation.
- Avoid awkward reaching.

COMMON INSTRUCTIONS

Film and Sheeting Overview

3M™ Controltac™ Plus Graphic Films 3M™ Controltac™ Plus Graphic Films with Comply™ Adhesive 3M™ Scotchlite™ Graphic Films with Comply™ Adhesive

- The pressure-activated adhesives on these films have a positionability feature.
- If part of the graphic prematurely sticks to the substrate in the wrong place, and firm pressure has not been applied, the graphic can be repositioned.
- Applying light pressure allows the film to be tacked in place for temporary positioning.
- Firm pressure to the film surface brings all the adhesive in contact with the substrate.

Note: The positionability feature of these films is lost if the film is removed from the liner and firm pressure is applied, whether you reapply the film back on its original liner, apply it to another liner, or apply it to a substrate.

- The Comply adhesive feature is available on selected Controltac Plus films and Scotchlite films. It allows air to move laterally through the adhesive. You can identify this feature by the texture on the liner.

3M Graphic Films, 3M™ Scotchcal™ Graphic Films and 3M™ Scotchlite™ Graphic Films and Sheatings

The adhesives on these films are pressure-sensitive and adhere quickly to the substrate upon contact.

✓ Important Note

Refer to Instruction Bulletin 5.31 for specific information on how to apply films with Comply adhesive, including using 3M™ Power Grip Tools.

Tools

- Scotch® Masking Tape, 2 inch wide
- 3M™ Plastic Applicator PA-1 (Blue or Gold*)
 - The gold applicator is most generally used. It is stiffer than the blue applicator, which allows maximum application pressure.
 - The blue applicator is used when you need more flexibility. It is softer, which allows you to mold it around contours and corrugations.
- 3M™ Low Friction Sleeve SA-1*
- 3M™ Rivet Brush RBA-3*
- Pin or 3M™ Air Release Tool 391X*
- 3M™ Primer 94

- 3M™ Edge Sealer *
(Use the one recommended in the Product Bulletin)
- Cutting tools, such as a razor blade with a safety holder
- Industrial heat gun; must be capable of attaining 500° to 750°F (260° to 399°C), or equivalent
- Cotton gloves
- A 1/4 inch (0.6 mm) paint brush for applying edge sealer

*Available from 3M Commercial Graphics Division

Temperature and Environment

Apply graphics when the air, film and substrate temperatures are within the range specified in each film or film's Product Bulletin or Instruction Bulletin 5.35, *Applicator's Quick Reference for Vehicle Graphics*. The incorrect temperature may prevent the film from performing as expected.

Conditions that Affect Graphic Application

- Graphics applied above the maximum recommended application temperature may pre-adhere.
- Above the maximum recommended application temperature, graphics constructed of Controltac Plus films may lose their positionability feature.
- The temperature of the substrate must be above the dew point to prevent moisture from condensing on the surface.
- In very humid conditions, it may be difficult to keep the substrate dry.
- Below the minimum recommended application temperatures, films and sheatings become stiff and brittle. The adhesive cannot bond adequately with the substrate. In addition, Controltac Plus films without Comply adhesive can trap air, which can cause bubbling.
- Substrates may be heated in order to raise the surface temperature above the minimum specified. Use an appropriate portable heater or heat lamps. Always check to ensure that heat will not damage the substrate.

Substrate Preparation

See Instruction Bulletin 5.1 for details on cleaning specific substrates and any special application techniques that are required.

- All substrates must be considered contaminated and must be cleaned prior to application of film or sheeting.
- If your substrate has dirt or loose paint on it, that is what the film adheres to--not the substrate itself. If the film does not make enough contact with a clean, dry substrate, it will not stick well, leading to premature graphic failure.
- The final cleaning of the substrate must be done immediately before applying film. Dust and other contaminants can collect quickly on the substrate and prevent the film from adhering properly.
- Be sure the substrate, rivets and seams are thoroughly dry. Film adheres poorly even to a properly cleaned substrate if there is any remaining moisture around the rivets and seams.

Application Sequence

Unless otherwise noted, follow the General Procedures in Instruction Bulletin 5.5, *General Procedures for Interior and Exterior Dry Application*.

Shelf Life, Storage and Shipping

- Unprocessed film has a shelf life of 2 years after receipt from 3M. Processed film has a shelf life of 1 year. However, the total shelf life of a graphic before and after processing cannot exceed 2 years.
- Store the film in the original container.
- Store the film in a clean dry area, out of direct sunlight and at less than 100°F (38°C) and 80% relative humidity.
- Ship the finished graphic lying flat or roll the graphic. To roll the graphic, wrap it image-side out onto a core that is 6 inches (15 cm) or larger in diameter. These methods help prevent the liner and application tape from wrinkling or popping off.

SPECIAL APPLICATIONS

Pump Skirts

Each pump skirt is slightly different, especially at older service stations. The following are general guidelines for installation.

1. Remove the pump skirt.
2. Prepare the substrate by removing dents, feathering chipped paint, and removing existing graphics.
3. Remove all hardware, locks, side shields, shoulder pads, rubber bumpers, etc.
4. Clean the pump skirt, including the back side of the skirt where the film will wrap around it. Follow the cleaning procedures in Instruction Bulletin 5.1.
5. Refer to the application procedures in Instruction Bulletin 5.1.
6. To reduce bulk so that the film wraps neatly around the pump skirt, you need to cut away some film. In this example, you would cut the film on solid lines and remove the white sections. See Figure 1.
7. Apply and wrap the film around the pump skirt, following the steps below and referring to Figure 2.

Note: As you wrap the edges of the film, keep in mind that you want the overlaps to be positioned downward, so moisture is less likely to seep under the film.

- Step 1** Apply the film to the face.
- Step 2** Apply the film to the bottom. Wrap or cut back the edge at a 45° angle.
- Step 3** Apply the film to the sides. Wrap or cut back the edge at a 45° angle.
- Step 4** Apply the film to the top and wrap or cut back the edge at a 45° angle.
- Step 5** Wrap and apply the triangular pieces of film, which extend from the sides, around the corners. Trim as needed.

8. Carefully cut an **X** from corner to corner in all openings where hardware, gages, etc. are located. Trim and fold back the film. Squeegee firmly. See Figure 3.

Cut out areas approximately as shown in white

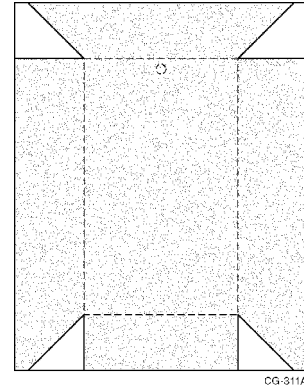

Figure 1 Cutting Diagram for Pump Skirt

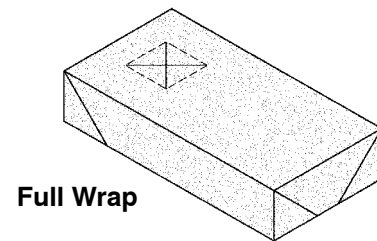
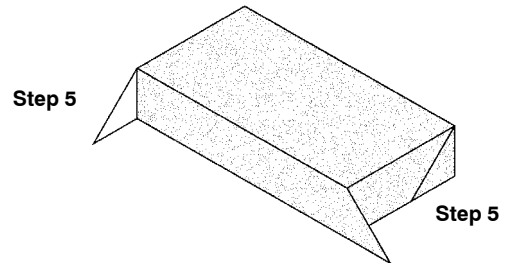
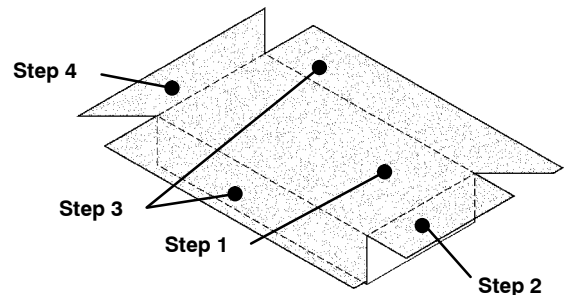

Figure 2 How to Wrap the Corners

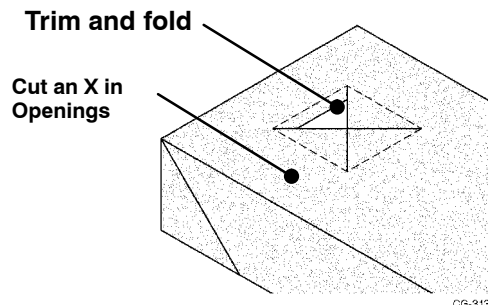

Figure 3 Cutting For Openings

Complex Curves and Contours

Covering complex curves and contours requires special techniques, including heating and stretching the film. Films have differing abilities to stretch, so the amount of heat and tension depends on the graphic construction. The specific characteristics of a film, as well as whether the shape is concave or convex, determines how well the film holds to the curved substrate.

Before deciding to heat and stretch film, check your panel placement to determine if it can be applied simply using the techniques for corrugations. See page 7.

Determining Which Films Can Be Stretched

Graphics made with the following constructions are rated below from easiest (1) to hardest (4) to stretch:

1. 2 mil vinyl
2. 2 mil vinyl with an overlamine
3. 4 mil vinyl
4. 4 mil vinyl with an overlamine

Graphics made with the following constructions cannot be stretched, and, therefore, are not warranted for use on complex curves and contours surfaces:

- Film with polyolefin as a base film
- 3M™ Scotchlite™ Reflective Film (stretching damages the reflectivity)
- Polyester base film or overlamine

Planning the Application

- **Panel placement:** Lay out the graphics to determine the panel placement. If stretching is needed, be sure to follow the instructions that follow.
- **Overlapping panels:** When applying multiple, overlapping panels, be sure the overlaps cannot trap and collect moisture. On a vehicle, be sure the overlaps face away from the air flow.
 - Vertical overlap (vehicles only): start at the back of the vehicle, and then work around toward the front.
 - Horizontal overlap: start at the bottom of the substrate and work up.
- **Temperature:** For ease of application, apply the film at room temperature or above, but not higher than the maximum recommended application temperature. Refer to the film's Product Bulletin or Instruction Bulletin 5.35, *Applicator's Quick Reference for Vehicle Graphics*, for details.

⚠ Caution

Heat or open flames may contribute to a flash fire or burns. Follow these precautions when using a heat source for flame treating.

- Read and follow the instructions supplied with the heat source.
- Avoid personal contact with the heat source. Wear heat-resistant gloves and safety glasses.
- Do not use heat sources near solvent mixtures or residues, or where solvent vapors may be present.

⚠ Caution

Always provide adequate ventilation to remove emissions that may result from the use of heat. Failure to provide adequate ventilation can result in operator exposure.

Convex Contours

Note: Depending on the severity the curve, the film may bunch up or ruffle at the edges and cause wrinkles.

1. Clean the substrate thoroughly using detergent and water followed by a solvent wipe.
2. Apply the graphic to the largest flat area first, then to other large flat areas.
3. If there is only a light bunching or ruffling, you may be able to shrink the edges of the film slightly by applying gentle heat before squeegeeing.
4. To eliminate heavier bunching or ruffling:
 - a. Cut to a point where the film lays flat. See Figure 4.

Illustration shows convex surface such as on the rear of a tanker.

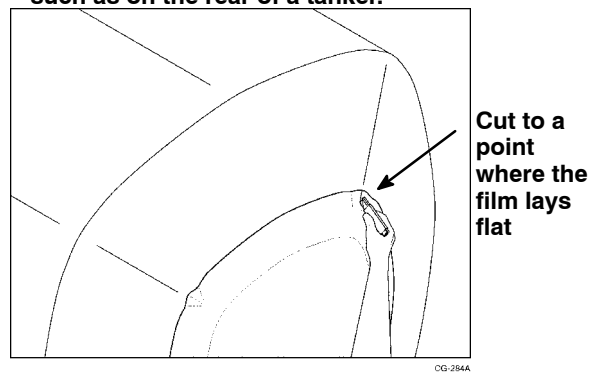

Figure 4. Cutting The Excess Film

- b. Overlap the excess film so that the upper piece overlaps the lower piece. See Figure 5.
5. Make absolutely sure that the contact areas are clean, and then wrap the cut film edges around the hood, door, window and/or trunk openings.

Note: The most common reason for graphic failure (edge lifting) at seams and openings is dirt or other contamination.

Concave Contours

1. Clean the substrate thoroughly using detergent and water followed by a solvent wipe.
2. Use primer 94 to help the film adhere in concave and corner areas.
 - This primer works well with most films.
 - It is not suitable for films with an adhesive that is “removable with heat only,” which includes film series 160, 8640 and all perforated window graphic films.
 - Removing films from areas that are primed is more difficult than removing film from unprimed areas.

Procedure

- a. Shake well before using.
 - b. Apply the primer as thinly as possible in a uniform coating. Apply it **ONLY** in the base or small radius areas; not the entire contour.
 - c. Allow the primer to dry.
 - d. Clean off any excess primer with isopropyl alcohol.
3. Apply the graphic to the largest flat area first, then to other large flat areas.
 4. Remove the application tape, if it is present.
 5. Heat the film until it becomes soft and conformable.

Important Note

Keep these points in mind as you learn to judge how much heat is the right amount.

- Heat softens the adhesive, which assures good initial adhesion.
- The right amount of heat allows the graphic to be stretched so that it will conform to the complex contour.
- Too much heat makes the films too soft and difficult to handle. It can also melt or shrivel the film.
- Insufficient heat may cause the film to tear rather than stretch. It may also eventually lift out of the recesses.

6. Gently stretch, push or form the film into the concave area with your hands. Wear cotton gloves for protection. See Figure 6.

Important Note

Stretching the film too much can cause tears and breaks.

7. Wherever the film has been stretched and formed into channels and corners, carefully make a single cut through the film along the entire length of that channel or corner. Be careful not to damage the substrate. Cutting relieves the stress on the stretched film and prevents the graphic from tenting. If the film has not been sufficiently heated and/or it has been stretched too much, it may shrink slightly in the cut area.

Note: Cutting too deeply will permanently damage the substrate.

8. Remove all trapped air using a pin or air release tool.
9. Carefully cut all substrate seams and openings such as body panel, hood, door, window and/or trunk seams.
10. Make absolutely sure that the contact areas are clean, and then wrap the cut film edges around the hood, door, window and/or trunk openings. Primer 94 can be used in these areas to ensure better adhesion.

Note: The most common reason for graphic failure (edge lifting) at seams and openings is dirt or other contamination.

11. Heat the edges and re-squeegee all seams, film edges and cuts.

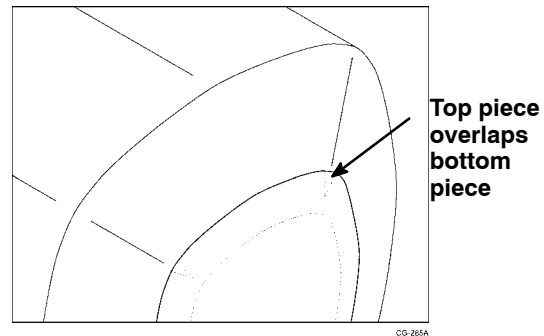

Figure 5. Overlapping The Cut Film

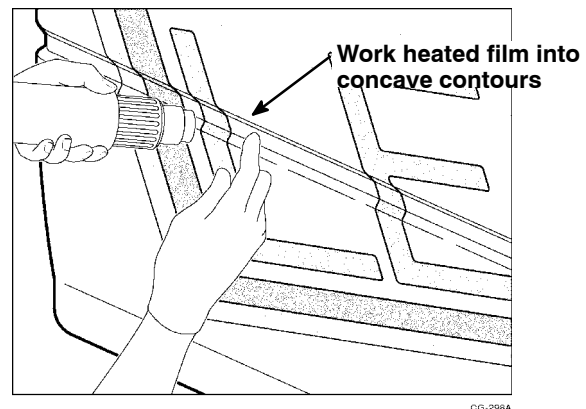

Figure 6. Working Film Into Concave Contours

VEHICLE APPLICATIONS

Buses

Warning

Special Bus Application Safety Information

The Office of Vehicle Safety Compliance of the U.S. National Highway Traffic Safety Administration (NHTSA) has asked for 3M's assistance in communicating an important safety concern. NHTSA has observed that graphic films used for bus wraps could be, and in some cases have been, applied in such a way as to block or restrict emergency window exits.

Penalties For Non-compliance

Failure to trim film away from rubber gaskets surrounding emergency exit windows can render an emergency exit inoperable. This is a violation of Title 49 United States Code section 30122. Substantial civil penalties as set forth in Title 49 United States Code section 30165 may be incurred for such a violation.

Additional techniques for applying permanent, changeable or removable graphics are similar to that of other vehicles. Use the following techniques in conjunction with Instruction Bulletin 5.5, *General Procedures for Interior and Exterior Dry Applications*.

Also see **Vehicle and Store Windows**, page 15.

1. Inspect the bus for areas that have the potential for paint failure. Any visible signs of paint peeling, lifting or bubbling, or rust indicates poor paint to substrate adhesion. Areas to pay special attention to are:
 - Bus rear
 - Wheel wells
 - Air intake vents
 - Windows
 - Rub rails
 - Air conditioning grills
2. Repair any problem areas according to the manufacturer's instructions, including the application of a prime coat. Only a **fully cured** prime coat is needed.
3. Clean the bus thoroughly. Pay special attention to oily areas such as the rear of the bus.
4. Document all places where paint adhesion may be a problem. Obtain a customer sign-off using the Pre-installation Review found in Instruction Bulletin 5.36, *Application: Special Considerations for Complex Contours of Automobiles, Vans and Buses*. A signed review is required as a condition for warranty on buses. See the **3M Related Literature** section.
5. Film may not adhere to certain areas of the bus, including:
 - Rubber
 - Window and door gaskets
 - Plastics

Conspicuity

For application methods and graphic placement, see:

- Instruction Bulletin 5.13, *Application, 3M™ Scotchlite™ Diamond Grade™ Conspicuity Marking Series 981*
- Instruction Bulletin 5.12, *Cutting and Applying Curtain Sided Vehicle Film*

Corrugations

The correct application method is to wrap the film around the corrugations. Do not bridge the film from one corrugation to the next and then use heat to push the film into the flat area. The film will tent in the valleys and cause the graphic to fail prematurely.

The profile of a standard corrugation has flat areas alternating with raised, rounded areas. Figure 7 identifies the parts of the profile by name.

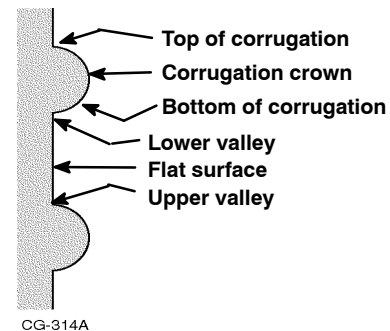

Figure 7 Profile of a Standard Corrugation

Applying Film To Corrugated Surfaces

1. Review Instruction Bulletin 5.5, *General Procedures for Interior and Exterior Dry Applications*, for pre-application information and hinge methods.
2. Position the film so that the top edge is on a flat surface and not a corrugation.
3. For multi-panel graphics, start 1/3 to 1/2 the distance down from the top edge of the film. This minimizes stretching and registration problems.

Application Technique for Corrugated Surfaces

Note: Be sure to use a gold or blue plastic applicator (also called a squeegee) for this procedure. The blue applicator is softer and allows you to conform it around corrugations.

1. In the application sequence that follows, use these four techniques in each step. Each step shows the correction position to hold and use the applicator tool.

Note: You can substitute a rivet brush for a plastic applicator in all of these sequences.

- a. Start all squeegee strokes near the vertical center of the film.
- b. Squeegee all the way to an edge.
- c. Return to the center.
- d. Starting at a place that overlaps the previous stroke by about 50%, repeat the procedure to the opposite edge. Use this technique for the upper valley, top of the corrugation, the corrugation crown, the bottom of the corrugation, and the lower valley. See Figure 8.

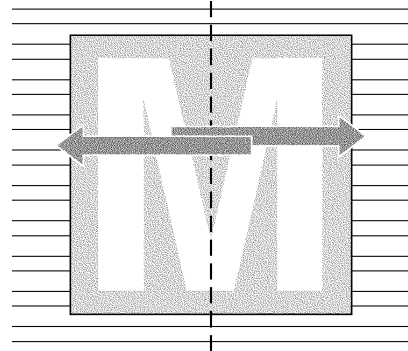

CG-315A

Figure 8 Overlap Your Squeegee Strokes

2. Use the edge of the plastic applicator in a continuous motion to bead the upper valley. See Figure 9.

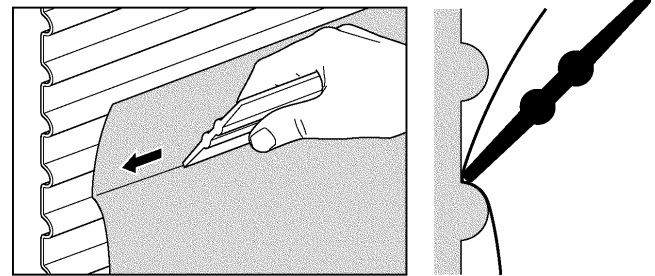

CG-316A

Figure 9 Bead the Upper Valley

3. Apply the film to the top of the corrugation with the corner of the plastic applicator. See Figure 10.

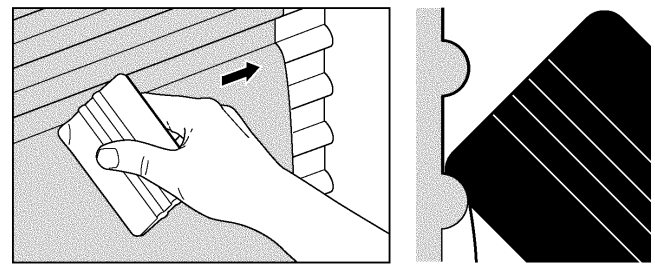

CG-317A

Figure 10 Squeegee the Top of the Corrugation

4. Squeegee the film along the crown of the corrugation using the edge of the plastic applicator. Use enough pressure to make the plastic applicator curl around the corrugation crown. This makes the film drape under the corrugation without pre-adhering it to the flat surface below. See Figure 11.
5. Conform the film around the bottom corrugation.

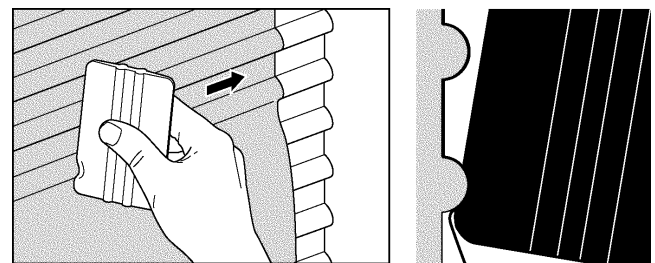

CG-318A

Figure 11 Squeegee the Crown of the Corrugation

Option 1:

- a. Use your thumb to firmly press the film along the corrugation's bottom and lower valley. This step conforms the film around the bottom corrugation, reducing the amount of film stretching and wrinkling. We recommend wearing a glove as this technique tends to be abrasive on your skin. See Figure 12.

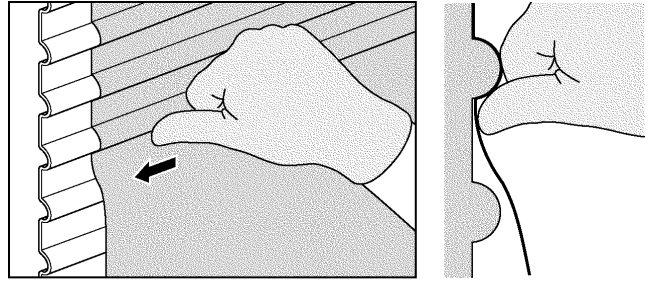

CG-319A

Figure 12 Conform the Lower Valley with Your Thumb

- b. Squeegee the bottom corrugation with the corner of the plastic applicator. The thumb method alone does not adequately adhere the film to the surface. See Figure 13.

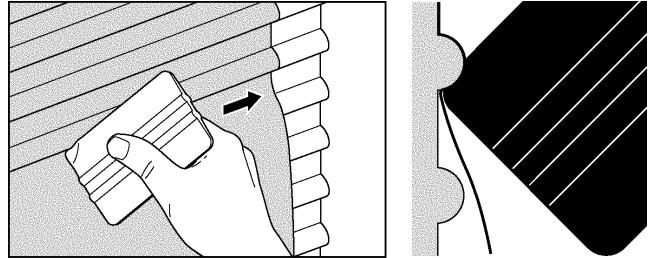

CG-320A

Figure 13 Squeegee the Bottom Corrugation

Option 2:

You can use a rivet brush for any corrugations where the distance between corrugations is 1.5 inches (3.8 cm). Do not use a rag. See Figure 14.

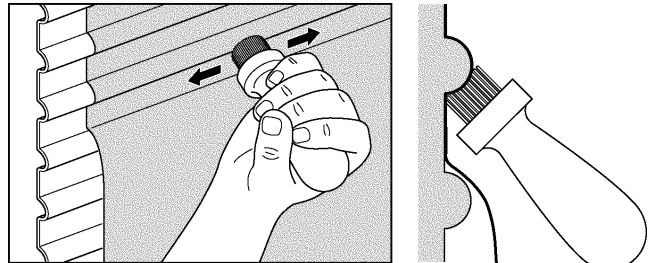

CG-321A

Figure 14 Conform the Lower Valley with a Rivet Brush

6. Bead the lower valley using the edge of the plastic applicator. The thumb method does not adequately adhere the film to the surface. See Figure 15.

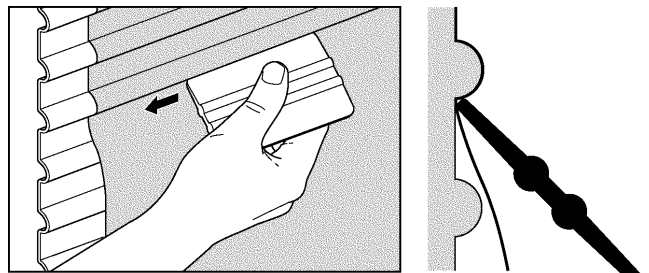

CG-322A

Figure 15 Bead the Lower Valley

- Apply the film to the flat area.

Option 1: Squeegee the film, starting from the lower valley and moving to the upper valley of the next corrugation. Always start at the lower valley. Use overlapping strokes and firm pressure. See Figure 16.

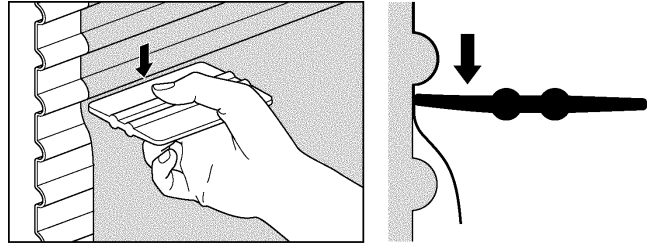

CG-323A

Figure 16 Use a Squeegee to Adhere the Film to Flat Areas

Option 2: An alternate method is to use the rivet brush. Avoid premature application to the top of the next corrugation. This causes the film to stretch. See Figure 17.

- Repeat steps 2 through 7 to the bottom of the graphic.
- To apply the top half of the graphic, repeat Steps 2 through 7 in reverse:
 - Adhere the film to the flat surface (Step 7).
 - Bead the lower valley (Step 6).
 - Conform the film around the bottom corrugation (Step 5).
 - Squeegee the film along the crown of the corrugation (Step 4).
 - Apply the film to the top of the corrugation (Step 3).
 - Bead the upper valley (Step 2).

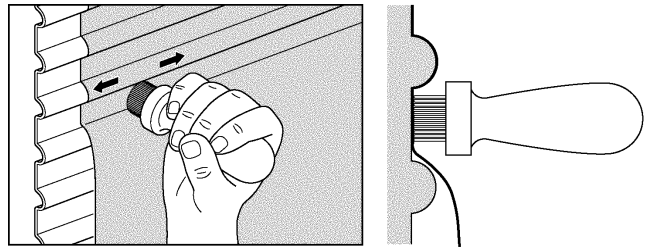

CG-324A

Figure 17 Use a Rivet Brush to Adhere the Film to Flat Areas

Finishing

Before performing the finishing steps, we recommend that you review the Finishing section of Instruction Bulletin 5.5, *General Procedures for Interior and Exterior Dry Applications*, which provides important details for successful finishing.

- Remove the application tape at 180° angle. See Figure 18.
- Re-squeegee all seams and outer edges with the plastic applicator and a low friction sleeve. Using firm pressure in an upward and downward motion. See Figure 19.

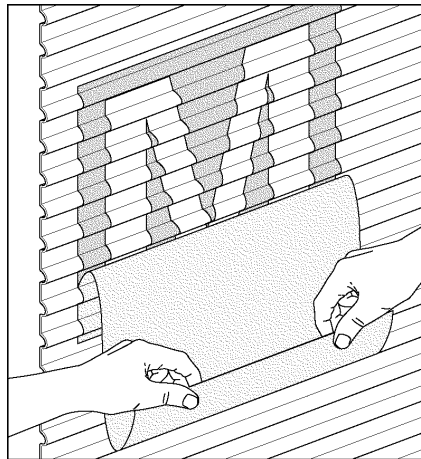

CG-325A

Figure 18 Remove Premasking Tape

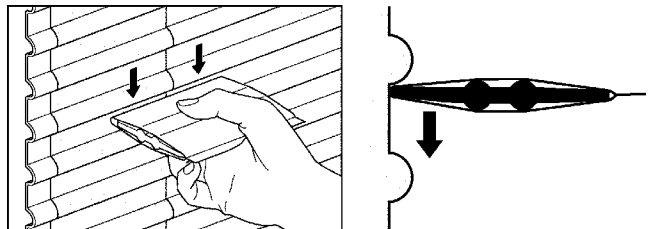

CG-326A

Figure 19 Re-squeegeeing the Seams

3. Re-bead the upper and lower valley of each corrugation at the film overlaps. Use firm pressure with the plastic applicator. Failure to do this step will result in lifting of the top film layer. See Figure 20.

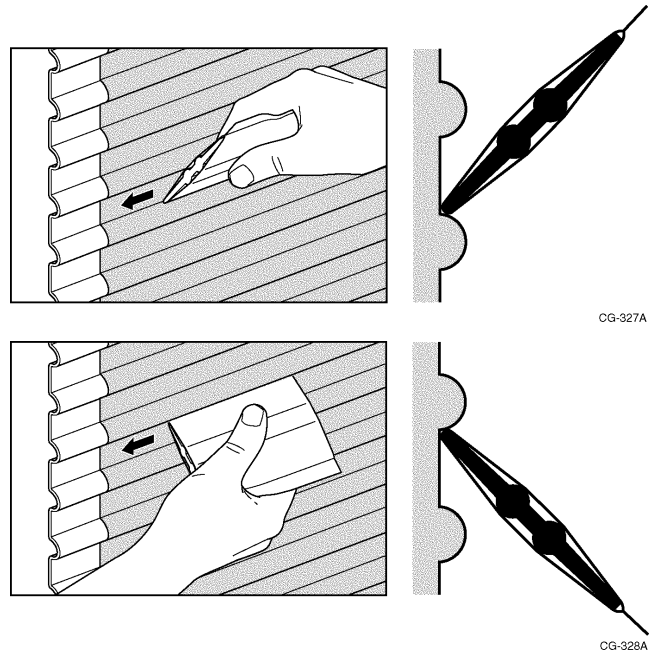

Figure 20 Re-bead Upper and Lower Valleys

4. Run your finger along the top and bottom of the corrugations to check for air bubbles. Remove any trapped air in the valleys. See Figure 21.
5. Follow the steps found in the **Finishing** section of Instruction Bulletin 5.5, *General Procedures for Interior and Exterior Dry Applications*.

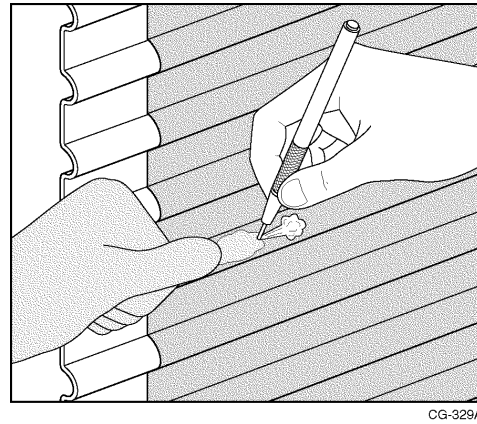

Figure 21 Remove Air Trapped in Valleys

Painted-in Graphics

Application tape can protect the graphic from staining when overpainted with most finish paints. This allows you to apply premasked graphics to the prime coat and then apply the finish coat. This method effectively edge seals the graphic by imbedding the graphic in the paint.

Note: The customer should test premasked graphics for paint resistance prior to using this technique.

1. Apply the film. See Instruction Bulletin 5.5, *General Procedures for Interior and Exterior Dry Applications*. Stop when you get to the **Finishing** section and return to this procedure. Do NOT remove the application tape.
2. Prepare the body seams.
 - a. Slit the film at all body seams with a razor blade or similar cutting tool. See Figure 22.
 - b. Then cover the slit body seams with a 2 inch (5.1 cm) wide strip of masking tape. See Figure 23.

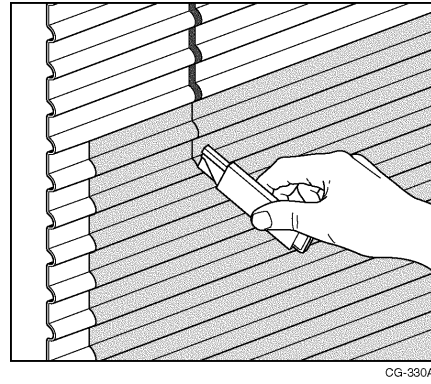

Figure 22 Slitting Body Seams

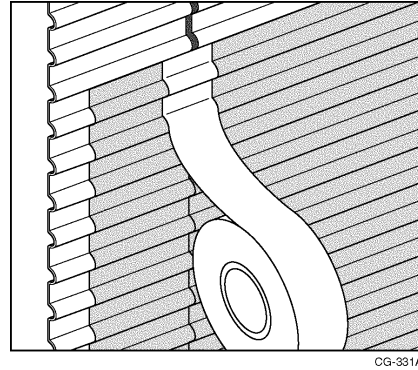

Figure 23 Taping Slit Body Seams

3. Apply multi-panel graphics. Refer to Figure 24.
 - a. Apply the first panel and squeegee in place.
 - b. Pull back the application tape approximately 1/2 inch (12 mm).
 - c. Apply the next piece of film over the edge of the first piece by 1/4 to 1/2 inch (6 to 12 mm). Do not apply the film over the application tape. Lay the application tape over the overlap.
 - d. Cover the seam with a 2 inch (51 cm) wide piece of masking tape.
4. Apply paint in the desired areas.

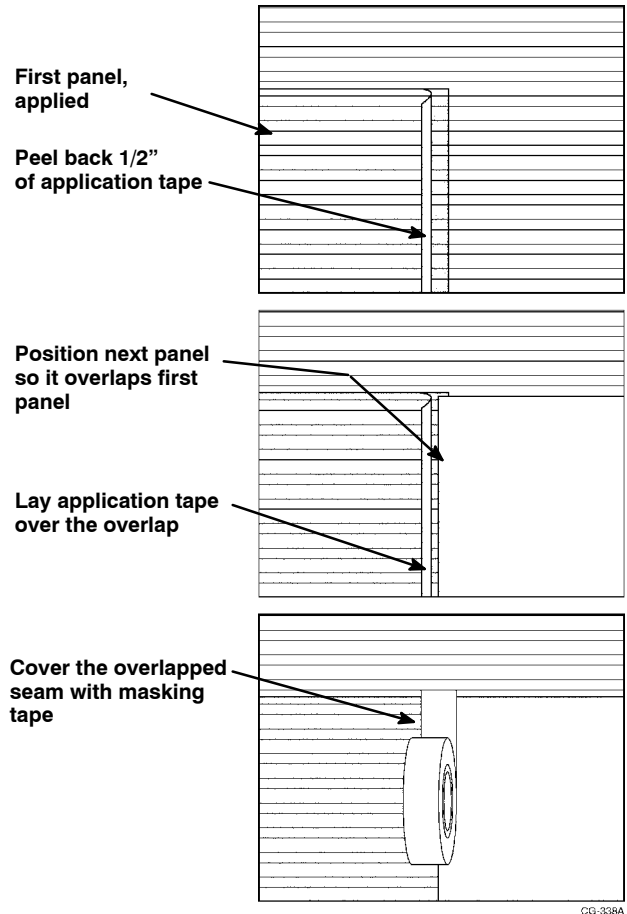

Figure 24. Applying Multi-Panel Graphics

5. While the final paint coat is still tacky but not wet, remove the application tape by pulling it directly back on itself at a 180 degree angle. See Figure 25.

Note: If the application tape will be left on during the paint's heat cycle:

- Test to make sure that the paint will not strike through.
- Test to make sure the application tape can still be removed after the heat cycle. Heat tends to increase the bond and you may not be able to remove the application tape.

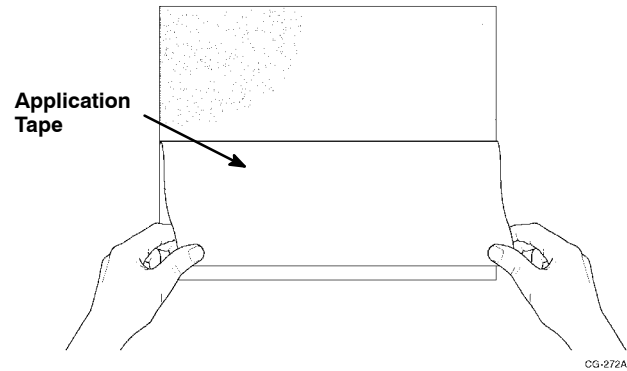

Figure 25 Removing Application Tape

Roll-up Doors

The film on roll-up doors must be cut at all door fold seams. This requires two cuts to remove a thin strip of film between each seam. Two common reasons for graphic failure (edge lifting) at these seams are: (1) dirty door fold seams, and (2) film that extends over the seam or is not securely adhered to the substrate.

1. Make sure that the inside of the door seam is washed clean and then dried. Lift the door enough to thoroughly clean the top and bottom lips of the panels. See Figure 26.
2. Check the door construction. If they are covered with plastic but are not painted, they require a specific film or special application technique. Refer to Instruction Bulletin 5.1 for cleaning and surface preparation techniques.
3. Apply the film. See Instruction Bulletin 5.5, *General Procedures for Interior and Exterior Dry Application*.
4. Remove the application tape.
5. Hold the cutting tool at a 45° angle and cut along both edges of the door fold seam. Remove the thin strip of film. See Figure 27.
6. Separate the panels by moving them apart as far as possible.
7. Heat the edges and squeegee the film, starting in the center and working to the edges.
8. Edge sealing is optional.

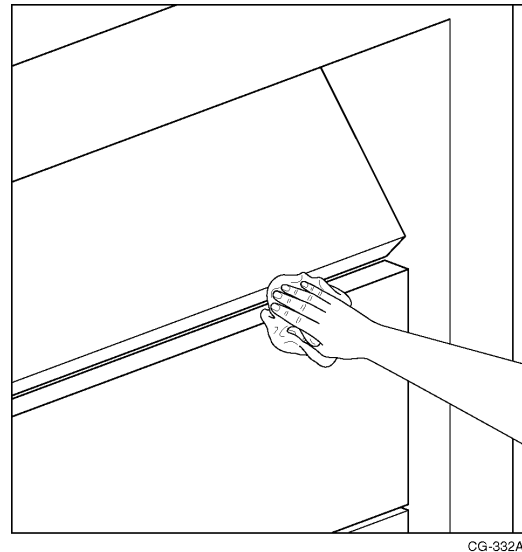

Figure 26 Cleaning the Door Fold Seams

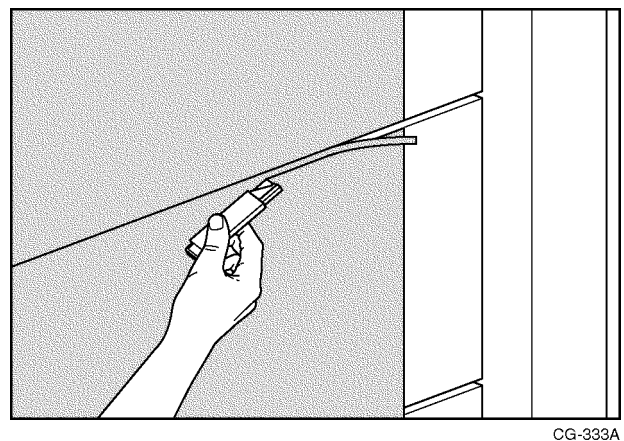
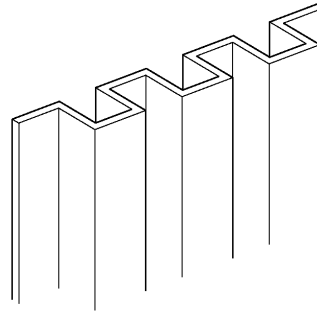

Figure 27 Cutting at the Door Fold Seams

Thermacube™ Trailers

Thermacube trailers have vertical corrugations. See Figure 28.



CG-334A

Figure 28 Thermacube Panels

1. Refer to Instruction Bulletin 5.5, *General Procedures for Interior and Exterior Dry Applications*. Use the vertical hinge method to start the application. See Figure 29.
2. Apply the film using the same squeegee techniques as for corrugations. See **Application Technique for Corrugated Surfaces** on page 8 of this bulletin.

Note: The film **MUST** conform to the vertical recesses.

3. Re-squeegee all outer edges.

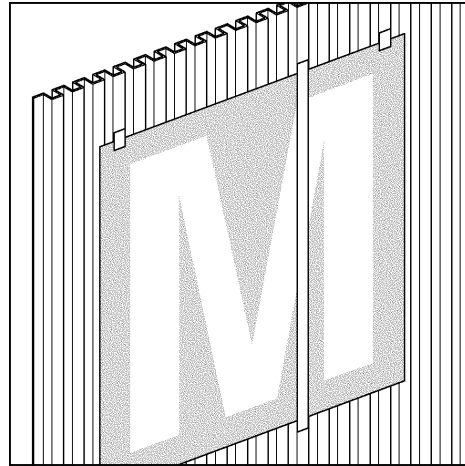

CG-335A

Figure 29 Vertical Hinge

4. Cut the film in the vertical recesses of the two inside corners. See Figure 30.
5. Cut the film at all panel overlaps.

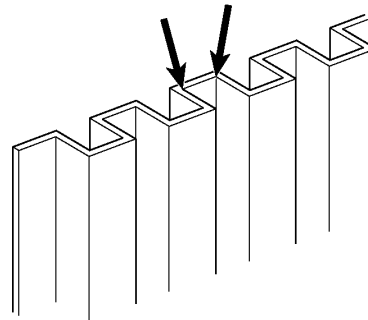

CG-336A

Figure 30 Cutting the Film In Recesses

Vehicle and Architectural Windows

Application Restrictions

The following uses and applications are specifically NOT recommended or warranted for perforated graphic film:

Restrictions for Architectural Graphics

- Non-vertical window surfaces.
- Windows with built-in heating or defrosting elements.
- Windows with coatings such as anti-reflection and scratch resistance.
- Window gaskets and rubber moldings.

Restrictions for Vehicle Window Graphics Only

- Graphics that are not trimmed away from all openings of any emergency window exit. See page 7 for further details.
- Windows with windshield wipers.
- Application to windows that crank or roll down, rubber moldings or window gaskets
- Non-laminated or improperly laminated film on exterior windows that require an optically clear view.

 Warning
Applications that require an optically-clear view, such as vehicle window exteriors, must be laminated with overlamine 8914. Failure to apply this overlamine could result in obstructed or impaired viewing when the product becomes wet.

- 3M Commercial Graphics Division policy is not to support applications of perforated window graphic film when a driver's view is obstructed and/or where local laws prohibit its use.

 Caution
Some states have laws or regulations requiring minimum light transmission that may limit or preclude the use of this product on regulated vehicle windows, which may include passenger vehicles and vans. The user is responsible for determining and complying with all applicable standards.

Application Tapes for Digital Images

Do NOT use an application tape (premasking or prespacing) on film that has been laminated with overlamine 8914. The adhesive of the application tape can pull the overlamine off the graphic.

Application Temperature

Do not apply graphics if the air or surface temperature is less than 40°F (4°C).

Safety Guidelines for Applying Vehicle Window Graphics

- Before applying film, open all emergency exit windows to determine exactly where graphics must be trimmed to ensure no interference with the operation of these windows.
- If an emergency window is non-functioning, it is your responsibility to alert the bus maintenance personnel before proceeding.
- Always trim the film 1/8 - 1/4 inch away from all rubber gaskets. Do not apply film over rubber gaskets.
- Do not allow any graphic film, whether applied to windows or bus body, to overlap the opening of an emergency window exit.
- After graphic installation is completed, ensure that all emergency window exits are fully functional.

Applying Perforated Window Graphic Film

Note: Before applying the film, be sure you understand what method of edge sealing will be used. See the next page.

1. Make sure that the glass is clean. Some glass has coatings that can prevent the graphic from adhering adequately. See Instruction Bulletin 5.1 for details on cleaning and how to determine whether there is a coating.
2. Always use a dry application method. Refer to Instruction Bulletin 5.5, *General Procedures for Interior and Exterior Dry Applications*.
3. Use a low-friction sleeve on the plastic applicator to prevent scratching.
4. During application:
 - Do not stretch the film into the window well or onto the window itself, which causes tension that can result in the graphic shrinking and its edges curling.
 - Cut the film to the approximate shape of the window before squeegeeing it. To do this, tack down the film in the center of the window, cut the graphic to shape, and squeegee the film to the window.
 - Do not use a heat source directly on the window. This can cause the film to shrink and its edges to curl.
5. When the application is completed and all window film has been trimmed, RESQUEEGEE all edges to ensure the best adhesion.

Painted Metal Surfaces Between Windows

If window graphic film is applied to narrow painted metal surfaces between windows, the image may not look consistent. To maintain a consistent image, an opaque 3M vinyl film may be applied to the surfaces between windows before the perforated film is applied. The color of vinyl film used depends on the image you want.

Seaming Side-by-Side Panels

If two panels are designed to meet side by side on a window, carefully trim the images so that the panels meet and form a butt seam. Do NOT overlap the panels. Always trim before starting the application. Do NOT cut the film while it is on the window as this may permanently scratch some window surfaces.

Edge Sealing Recommendations

Edge sealing improves the resistance to environmental damage and enhances the durability of the graphics. We recommend using one of these easy options on graphic edges.

You can order narrow rolls of overlamine 8914 from 3M. Use part number 75-3469-0233-3 and specify 1/2 inch x 50 yard (13 mm x 43 m) rolls, or you may cut 1/2 inch (13 mm) rolls from your inventory of overlamine 8914.

OPTION 1: Seal the edges with strips of overlamine.

This method can be used whether your graphic has overlamine 8914 or a screen printed clear coat applied.

Apply a 1/2 inch (13 mm) strip of overlamine 8914 so each strip evenly straddles the perforated film and substrate. Overlap the corners. See Figures 1 to 3.

OPTION 2: Apply an oversized piece of overlamine.

This method is for use by experienced applicators and should be used only on graphics that cover just part of a window or have irregular shapes.

Cut overlamine 8914 so it is at least 1/4 inch (7 mm) larger than the graphic and apply so it overlaps all edges of the perforated film. Contact us for more details, if needed. See Figure 4.

✔ Important Note

Never allow film or overlamine to touch the rubber window molding.

Figure 1. With strips of 8914, overlap glass by about 1/4 inch (7 mm). Also overlap corners.

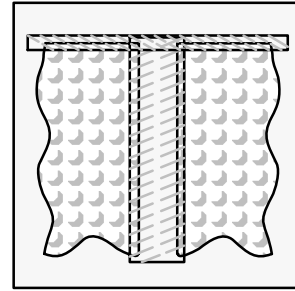

Figure 2. Where there is a small gap between windows, overlap entire gap with strips of 8914 so it extends about 1/4 inch (7 mm) onto perforated film.

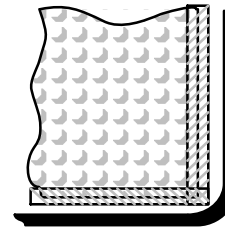

Figure 3. Where there is a rubber molding around windows, apply as in Figure 1, but not apply over any rubber molding.

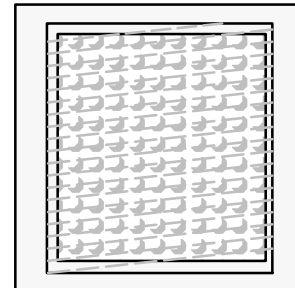

Figure 4. Overlap entire graphic with a single sheet of 8914 so it extends at least 1/4 inch (7 mm) beyond the edges of the graphic.

Sizing the Window

Measure the window opening and the graphic to make sure that it fits on the window. Apply the graphic and then cut away a margin of 1/8 to 1/4 inch (3 to 6 mm) all around the graphic. See Figure 5. This eliminates the need for edge sealing on full window coverage.

Do NOT apply the any film to any rubber gaskets or parts on the buses. This minimizes the chance of the graphic lifting, or absorbing water that may collect in the window edge. It also eliminates the need for edge sealing on full window coverages.

Do NOT allow any film to overlap the openings for any emergency window exits, which can prevent the window from operating properly in an emergency. See page 7 for further details.

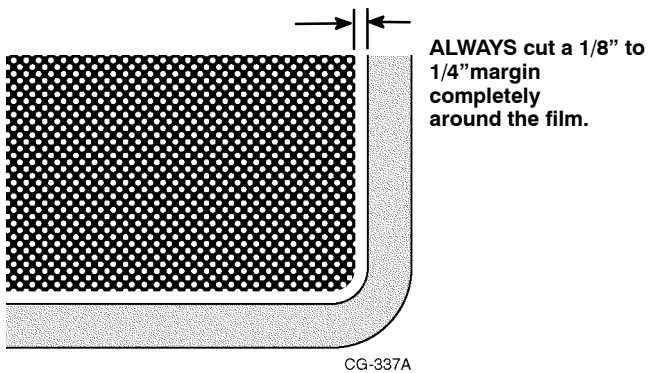

Figure 5 Leave a Space All Around the Window

Warranty and Limited Remedy

The information contained and techniques described herein are believed to be reliable, but 3M makes no warranties, express or implied, including but not limited to any implied warranty of merchantability or fitness for a particular purpose. 3M shall not be liable for any loss or damages, whether direct, indirect, special, incidental or consequential, in any way related to the techniques or information described herein.

3M Related Literature

Before starting any job, be sure you have the most current product and instruction bulletins.

The information in 3M bulletins is subject to change. Current bulletins, as well as a list of all bulletins updated within the last three months, are available at www.scotchprint.com or through our Fax-on-Demand system. Any warranty, if offered, is based on information in the bulletin that was current at the time you purchased the 3M products. The following bulletins provide the information and processes you need to properly make the graphics described in this bulletin.

Fax-on-Demand phone numbers:
United States or Canada: 1-800-364-0768
International: 1-651-732-6506

Subject	Bulletin No.	FOD No.
Instruction Bulletins		
Application: Substrate Selection, Preparation and Substrate-specific Application Techniques	5.1	7001
Application: General Procedures for Interior and Exterior Dry Applications	5.5	7005
Cutting and Applying Curtain Sided Vehicle Film	5.12	7012
Application, 3M™ Scotchlite™ Diamond Grade™ Conspicuity Marking Series 981	5.13	7013
Applying 3M Graphic Films with Comply™ Adhesive	5.31	7031
Application: Special Considerations for Complex Contours of Automobiles, Vans and Buses and Inspection Records	5.36	7036
Applicator's Quick Reference Guide for Vehicle Film	5.35	7035
Warranties		
Worldwide 3M™ MCS™ Warranty		9503

3M, Comply, Controltac, MCS, Scotchcal and Scotchlite are trademarks of 3M Company.

Thermacube is a registered trademark of Great Dane Trailers.

Bulletin Change Summary

Changed references to e-film to polyolefin film on page 5.
Updated the edge sealing recommendations on page 16.
Changed Comply Performance to Comply Adhesive.

3M

Commercial Graphics Division
3M Center, Building 220-12E-04
PO Box 33220
St. Paul, MN 55144-3220 USA
General Info. 1-800-374-6772
Technical Info. 1-800-328-3908
Fax 1-651-736-4233

Fax-on-Demand 1-800-364-0768 US/Canada or 1-651-732-6506 International
Fax-on-Demand document: 7004
www.scotchprint.com

3M Canada
P.O. Box 5757
London, Ontario
Canada N6A 4T1
1-800-265-1840
Fax 519-452-6245

3M México, S.A. de C.V.
Av. Santa Fe No. 55
Col. Santa Fe, Del. Alvaro Obregón
México, D.F. 01210
52-55-52-70-04-00
Fax 52-55-52-70-22-77

3M Puerto Rico, Inc.
Puerto Rico Industrial Park
P.O. Box 100
Carolina, PR 00986-0100
787-620-3000
Fax 787-750-3035

©3M 2005. All rights reserved.